

FEATURES

- Diode Board using for lamp test
- 10 Inputs and 10 Outputs
- Modular construction for easy assembly
- UL94 V-0 Class flame retardant green polyamide 66 PCB

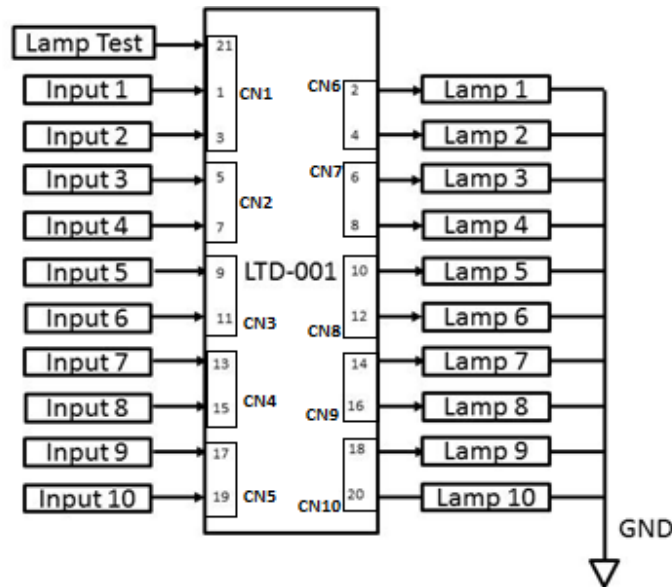

Wiring/ Application Diagram



Diode Board is generally for use in connection with lamp test panel. It comes with 10 inputs and 10 outputs. No additional screw is required to install the diode board, no additional wire is needed for the assembly, and the compact size with built-in input and output terminal blocks for easy wiring and termination.

Contact Information

Alphino Pte Ltd.
 (Co. Reg. No.: 20110 6361R)
 #03-110, 18 Boon Lay Way
 18 @TradeHub 21
 Singapore 609966
 MAIN (65) 6686 4923 FAX (65) 6468 5819
 Email: sales@alphino.com

TECHNICAL DATA

Operating Temperature	-20 °C to 70 °C
Storage Temperature	-20 °C to 80 °C
Connections	Input / Output
Current Rating	1A per input
Mounting Position	DIN Rail Mount
Dimension	45 L x 82 W x 43 H (mm)
Weight	62 g

ORDER INFORMATION

LTD	-	001
-----	---	-----

Alphino reserves the right to change products' specifications without prior notice as our commitment to continuous improvement.