

### INTRODUCTION

**Alphino 1E3 Beacon Series** is certified to use in Hazardous Zone 1 & Zone 2 as well as Zone 21 & Zone 22 as per IECEx standard and ATEX directive. The beacon also come with IP66 & IP67 housing in accordance of IEC 60529. Beacon tested to be dust-tight (Category 1 with vacuum pump connected) & resistant to water ingress from powerful water jets as well as protection to water ingress at 1M depth up to 30 minute. This test further demonstrates Alphino beacon's ability to reliably perform in the harshest environments.

**1E3 Beacon with Xenon Lamp:** Available with variety of energy level from 5 to 30 Joules. As default, flash rate is set at 60 per minute.

**1E3 Beacon with LED Lamp:** Available with LEDs with longer lifetimes. User can select 3-in-1 function (steady, flash and running/rotating) and interval by setting switch combinations which are provided on circuit board.

### Installation

#### Mounting

Alphino 1E3 Beacon Series can be mounted in any direction to walls or other surfaces. Two mounting bolts/nuts (size M8, not provided) are required for mounting. Figure 1 shows some example positions of the mounting positions. See Figure 10 for the fixing centers.

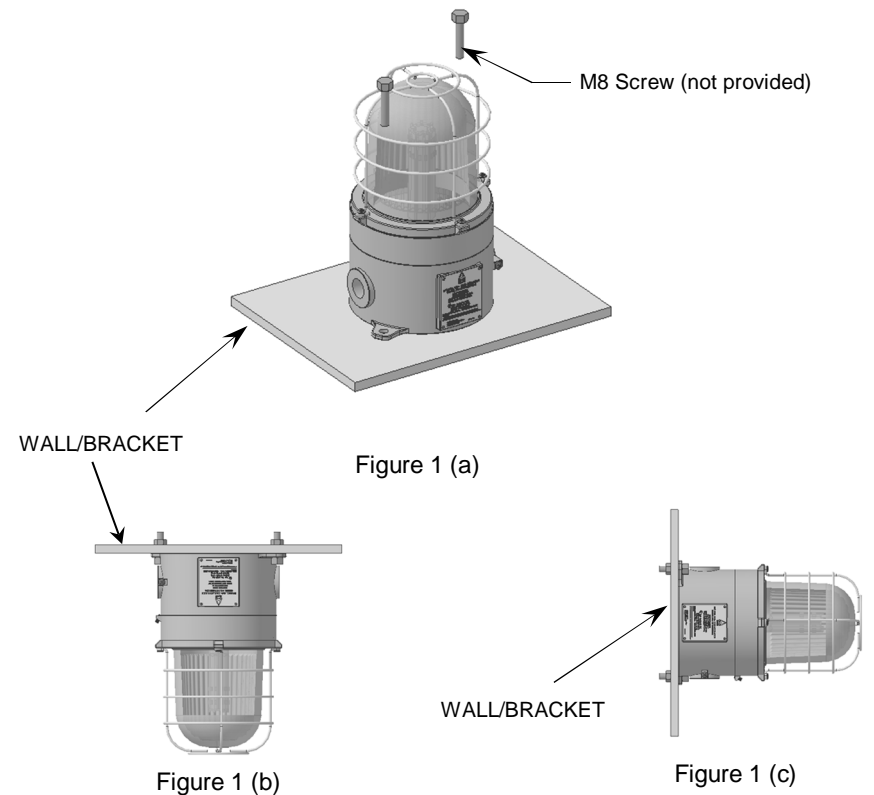

1(a), 1(b) and 1 (c): Examples of mounting beacon to various type of surfaces/directions

Notes:

- (1) According to material type of intended surface at where the beacon to be mounted, please use proper length of screw to withhold the beacon safely at the surface.
- (2) Additional fixture or washers and nuts (M8) may be used depending on type of mounting surface to ensure the beacon is mounted with proper safety.

## Cable Selection for Power Supply

Alphino 1E3 Beacon Series should only be operated with the appropriate power supply. Power supply cables should be chosen based on the capacity of the beacon lights connected to the line.

Table 1 & 2 shows rated input voltages, operation voltages and peak currents of various models.

**Note: Peak current indicated is for one lamp only.**

### Xenon Lamp:

| Operating Voltage | Average Current (mA) |     |      |      |      |      |
|-------------------|----------------------|-----|------|------|------|------|
|                   | 5J                   | 10J | 15J  | 21J  | 25J  | 30J  |
| 110VAC            | 365                  | 456 | 525  | 920  | 930  | 1000 |
| 230VAC            | 130                  | 220 | 225  | 405  | 432  | 585  |
| 24VDC             | 650                  | 920 | 1080 | 1340 | 1410 | 1600 |
| 48VDC             | 335                  | 475 | 550  | 710  | 750  | 870  |

Table 1: Xenon lamp Average current

### LED Lamp:

| Operating Voltage | Peak Current (mA) under Steady Operation Mode |
|-------------------|---|
| 12VDC             | 600   |
| 24VDC             | 300   |
| 48VDC             | 160   |
| 110VAC            | 150   |
| 230VAC            | 100   |

Table 2: LED lamp peak current

**SAFETY WARNING:** The cable entry temperature may exceed +70°C or the cable branching point temperature may exceed 93.5°C at high ambient temperatures and therefore suitable heat resisting cables and cable glands must be used, rated 105 °C for ambient temperatures of 70°C.

## Cable Termination



Alphino 1E3 Beacon series can either be powered directly by AC or DC sources or be initiated by telephone lines (for single color with telephone initiation model). See Alphino 1E3 Beacon series datasheet on the require type of beacon.

If the cable gland used is only suitable for fixed installations, cables must be effectively clamped to prevent, pulling or twisting. Ensure all cable glands used are ATEX/IECEX certified which must be suitable for the type of cable being used.

Un-used cable entry/entries (conduit entry/entries) must be closed with suitably rated and ATEX / IECEx certified blanking plugs so that the IP66/IP67 rating to the beacon is maintained.

Please follow the steps below to terminate field wirings.

1. Loosen the M4 set screw.
2. Untighten and remove the Top Enclosure.
3. Unscrew the 3pcs M3L5 pan head screw and remove the PCBA
4. Use certified cable gland at cable entry.
5. Terminate field wires as shown in Figure 4 or 5.
6. Ensure all field wires are secured to the terminal block.
7. Terminate with certified stopping plug to any of un-use cable entry.
8. Place the PCBA on top of stand-off and re-screw the 3pcs M3L5 screw.
9. Ensure the O-ring is seated correctly on Bottom Enclosure
10. Re-mount the Top Enclosure and tighten with torque value of 10-12Nm
11. Tighten the M4 set screw
12. Apply appropriate power supply to beacon light and check for correct operations.

General arrangement of cable entries (conduit entries) are as following figure 3:

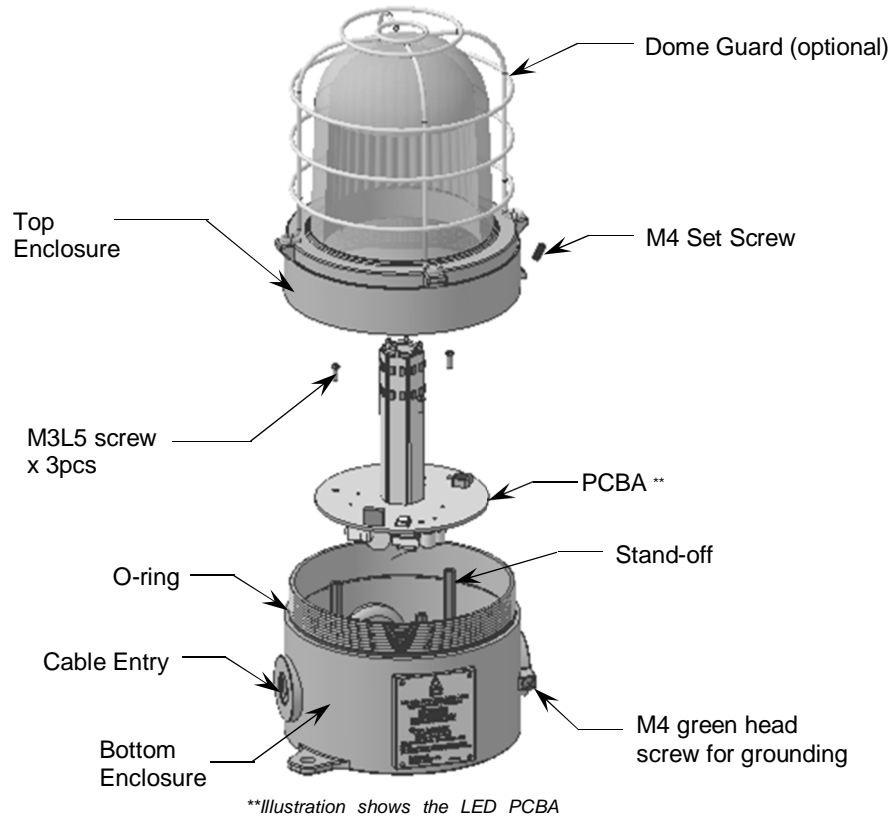

Figure 2: Various parts of an Alphino 1E3 Beacon Series

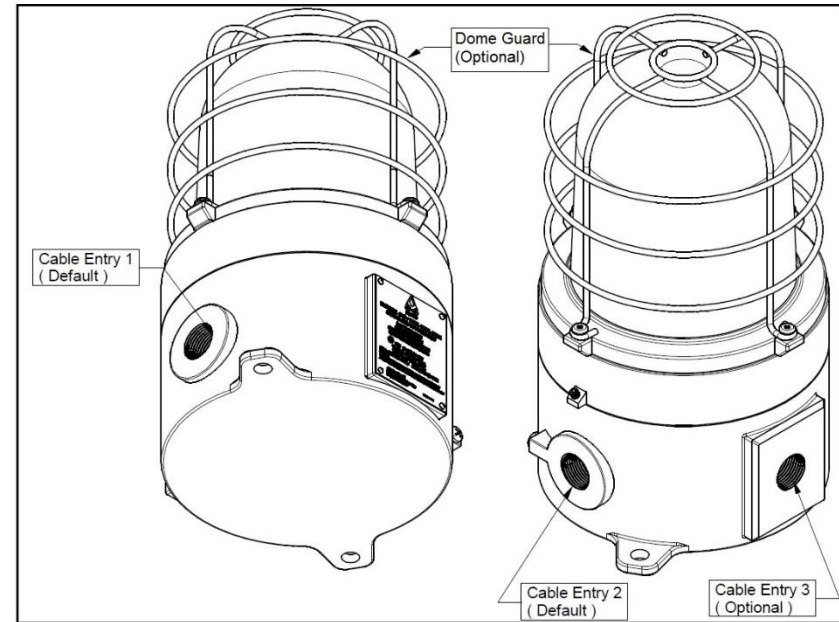

Figure 3: General arrangement of cable entries (conduit entries)

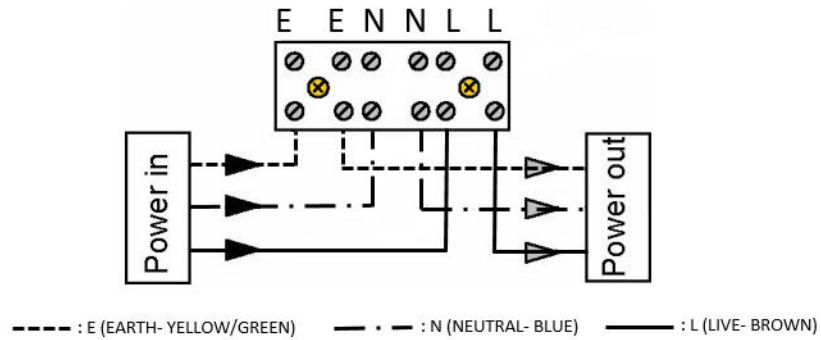

Figure 4(a): Wire connection diagram for 1E3 beacon with AC voltage supply

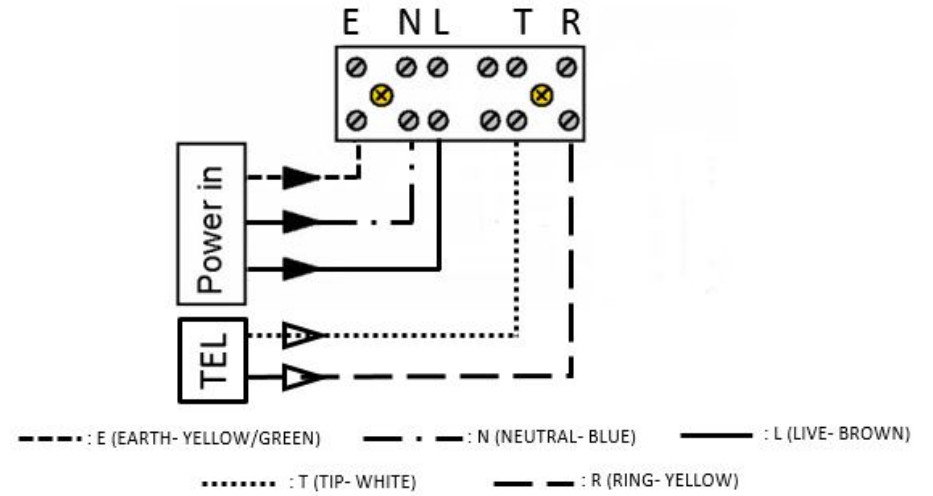

Figure 4(c): Wire connection diagram for 1E3 beacon with AC voltage supply and telephone initiation

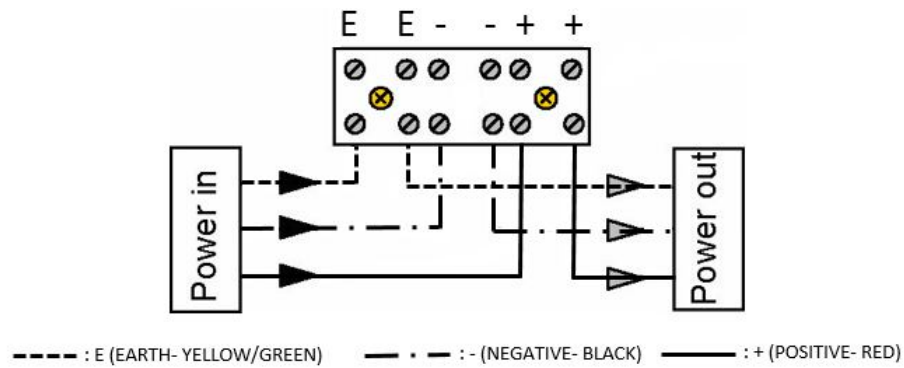

Figure 4(b): Wire connection diagram for 1E3 beacon with DC voltage supply

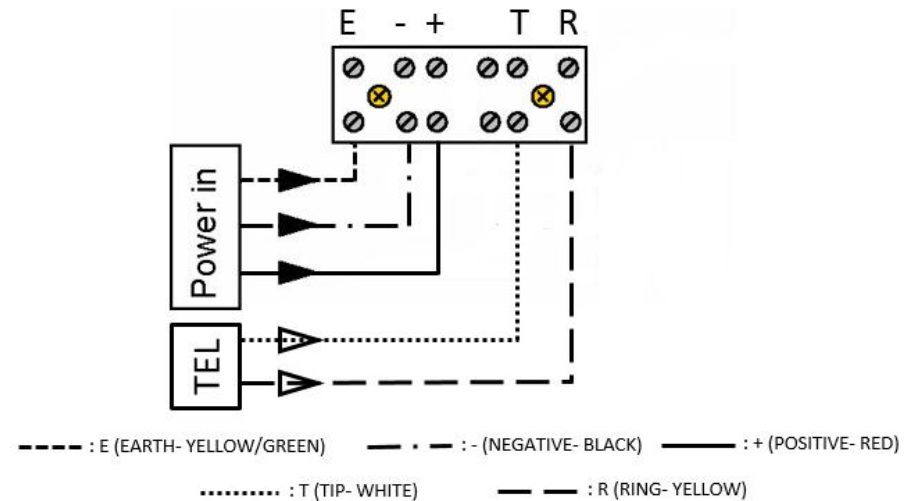

Figure 4(d): Wire connection diagram for 1E3 beacon with DC voltage supply and telephone initiation

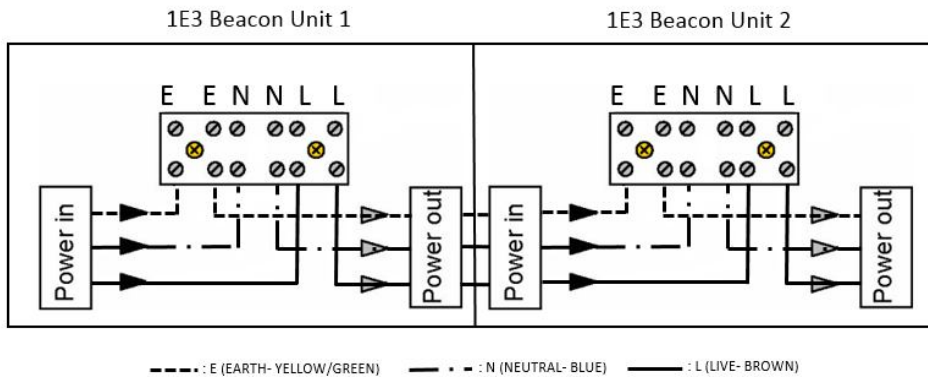

Figure 5(a): Wire connection diagram for multiple units with AC voltage supply

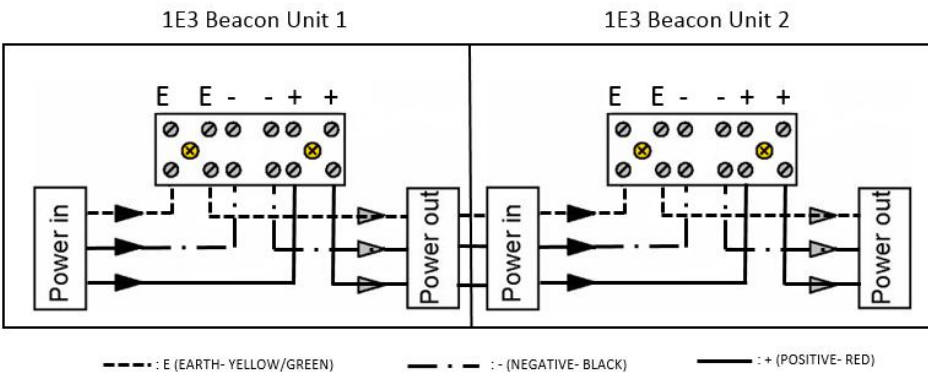

Figure 5(a): Wire connection diagram for multiple units with DC voltage supply

Table 3: Terminal block label for **AC** version

| Label | Description          |
|-------|----------------------|
| E     | Earth                |
| N     | Neutral              |
| L     | Live                 |
| T     | Telephone Line: Tip  |
| R     | Telephone Line: Ring |

Table 4: Terminal block label for **DC** version

| Label | Description          |
|-------|----------------------|
| E     | Earth                |
| -     | Negative(for DC)     |
| +     | Positive (for DC)    |
| T     | Telephone Line: Tip  |
| R     | Telephone Line: Ring |

## Safety Grounding

Alphino 1E3 Beacon series, both AC and DC beacon unit provides an internal and external grounding point for equipment grounding to ensure safety.

The external grounding point is provided for user to do earth grounding termination which is a M4 screw (green head) with a ground symbol (see Figure 2). All beacon units must be connected to earth grounding.

It is recommended to terminate earth grounding using a ring crimp terminal (not provided).

All external earth conductors must use a minimum 11 AWG or 4mm<sup>2</sup> cross section areas.

# Operation

Alphino 1E3 Beacon Series operating voltage is stated on the product label. The unit can be operate directly with power or initiated via a telephone signal if requested when order.

## Rate and Mode Adjustment (Only for LED Lamp)

Alphino 1E3 Beacon Series (LED version) support selectable rates and mode. User can select the required flash/rotate rate, which ranges from 30 to 180 flash/revolution per minute, by simply selecting the switch at SW1 the provided.

Figure 6 shows the various combinations of setting of the Beacon Light rates and modes. Figure 7 shows the position on the main PCB at which the switch is located.

| Comb. | Switch | Rate    | mode     |
|-------|--------|---------|----------|
| 1     |        | 0       | Steady   |
| 2     |        | 0       | Steady   |
| 3     |        | 30 rpm  | Rotation |
| 4     |        | 60 rpm  | Rotation |
| 5     |        | 80 rpm  | Rotation |
| 6     |        | 100 rpm | Rotation |
| 7     |        | 120 rpm | Rotation |
| 8     |        | 150 rpm | Rotation |
| 9     |        | 180 rpm | Rotation |
| 10    |        | 30 fpm  | Flash    |
| 11    |        | 60 fpm  | Flash    |
| 12    |        | 80 fpm  | Flash    |
| 13    |        | 100 fpm | Flash    |
| 14    |        | 120 fpm | Flash    |
| 15    |        | 150 fpm | Flash    |
| 16    |        | 180 fpm | Flash    |

Figure 6: Switch combinations for rate and mode setting

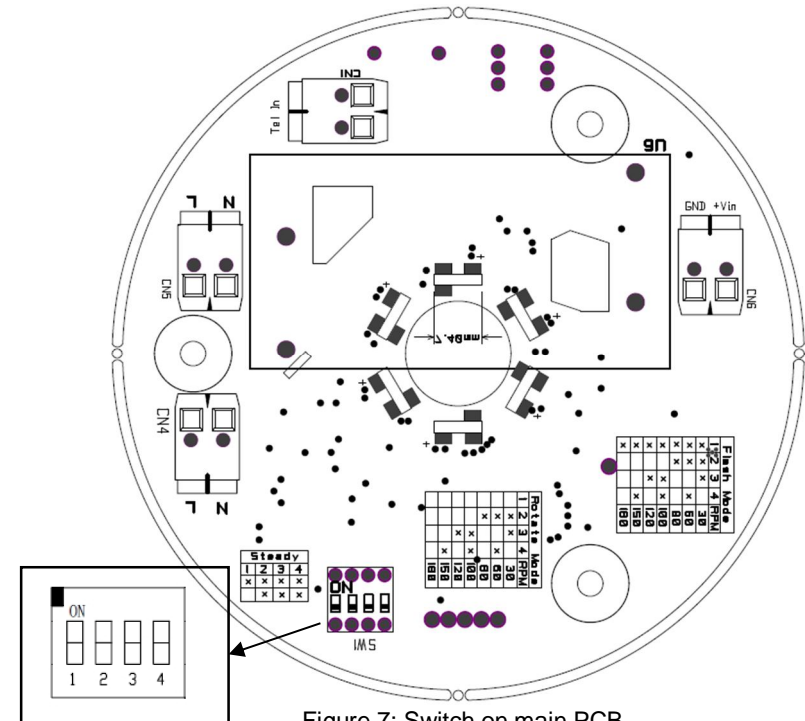

Figure 7: Switch on main PCB  
(Note: Pre-installed as default for 60 FPM)

## Maintenance

Alphino 1E3 Beacon Series require little or no maintenance during their working life. However, should there be abnormal conditions in a unit due to plant damage or accident, visual inspection of the unit shall then be carried out. If a fault occurs, it is recommended that the unit be returned to the manufacturer (Alphino Pte Ltd) for repair.

Maintenance of the unit must only be carried out by qualified personnel in accordance with the current relevant standards

Repairs of the flameproof joints must be made in compliance with the structural specifications provided by the manufacturer (Alphino Pte Ltd). Repairs must not be made on the basis of values specified in tables 1 and 2 of EN/IEC 60079-1.

### **EN 60079-17/IEC60079-17**

Explosive atmospheres - Electrical installations inspection and maintenance

### **For removal / replacement of xenon tube**

All Removal / replacement of xenon tube are to be done in the safe zone with a certified electrician

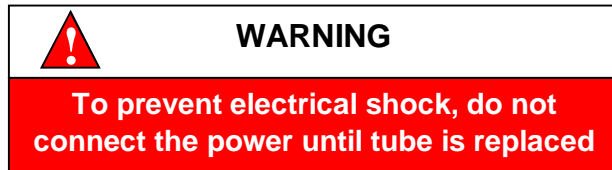

Ensures that power is isolated from this beacon unit before disconnecting  
For Xenon beacon, 21J, 25J and 30J consist of 2 tubes and 5J, 10J and 15J consist of 1 tube. These tubes are hold by a terminal block.

With the beacon remove to a safe area, untighten the top enclosure of the beacon. Measure the voltage across the xenon tube with a multi-meter to ensure it is being discharge to a safe voltage (10VDC) before removing the tube.

After it being discharge, remove the tube from the fix terminal block. The replacement tube be can replace now. (See xenon tube (BOM part no.: 100511) installation sheet, which is supplied with the replacement tubes)

After new tube is replaces, tighten the top enclosure of the beacon and ensure the O-ring is seated correctly.

## Special Conditions for Use

1. The cable gland used is only suitable for fixed installations. Cables must be effectively clamped to prevent, pulling or twisting.
2. Repairs of the flameproof joints must be made in compliance with the structural specifications provided by the manufacturer (Alphino Pte Ltd). Repairs must not be made on the basis of values specified in tables 1 and 2 of EN/IEC 60079-1.
3. According to material type of intended surface at where the beacon to be mounted, use proper length of screw to withhold the beacon safety at the surface.



# Dimensions

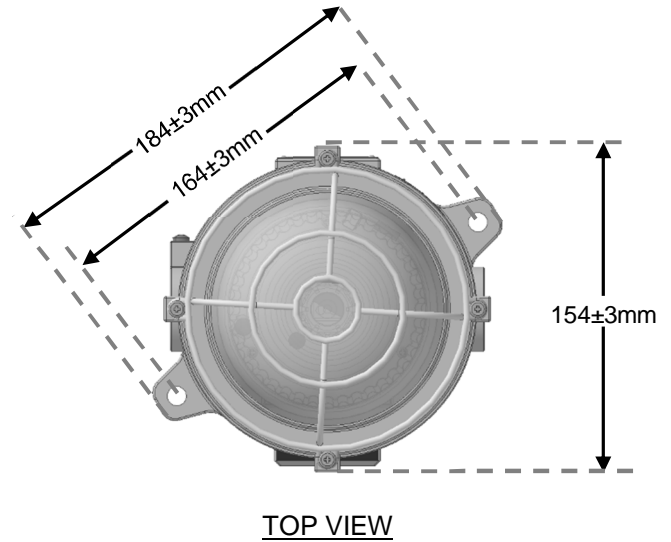
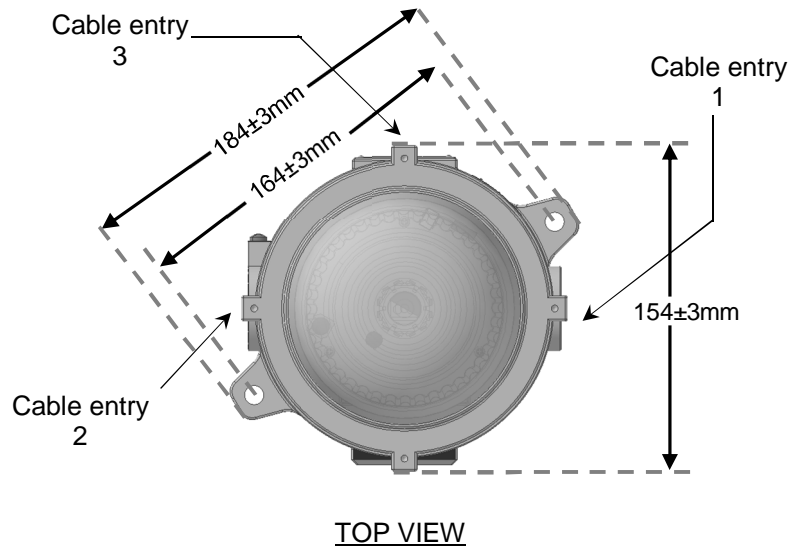
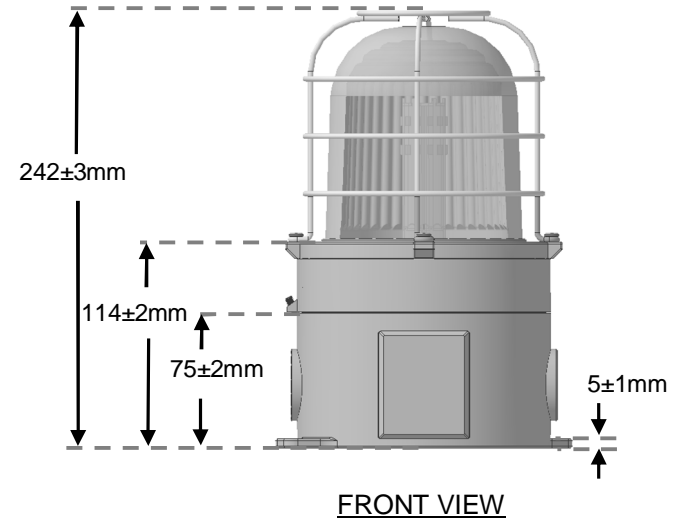
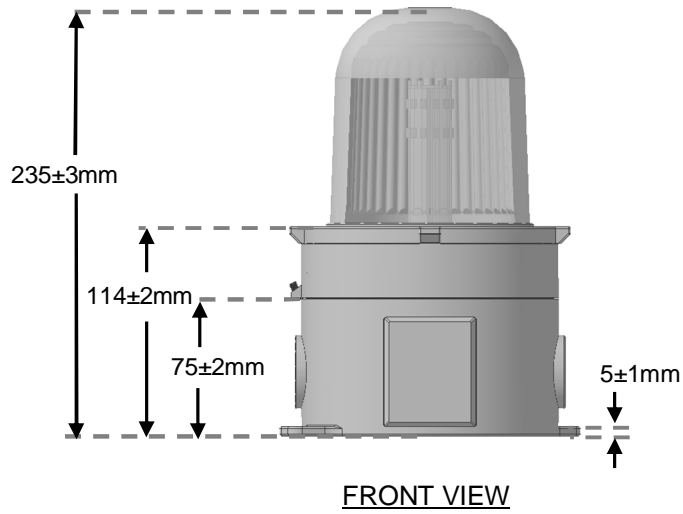

Figure 8: Front and side views without dome guard  
(Note: All dimensions shown are in mm)

Figure 9: Front and side views with dome guard  
(Note: All dimensions shown are in mm)



## Fixing Centers

1E3 beacon requires 2 pieces of M8 screws for mounting. Figure 10 shows the mounting centers.

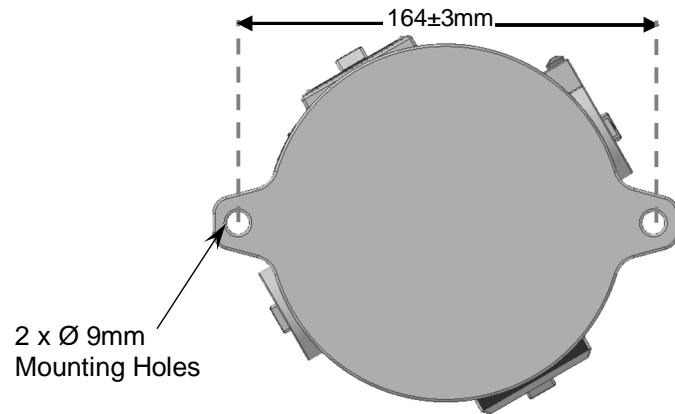

Figure 10: Bottom view which shows mounting holes

## Fixing Name Tag

In case of name tag is required for unit identification, recommended dimension for the sticker name tag size is shown in figure 11.

\*\*\*Only for 1E3 beacon with 2 cable entries. Not applicable for 1E3 beacon with 3 cable entries\*\*\*

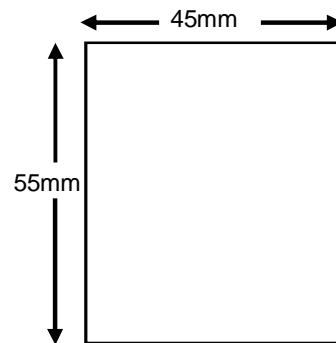

Figure 11: Outline view which shows the recommended name tag size.

(Note: Name Tag is not provided with beacon unit)

## Certification/Approvals

Certificate No.  
PRESAFE 17 ATEX 11772X  
IECEX PRE 17.0028X

### Xenon Beacon Certified

ATEX: Ex II 2 GD, Ex db IIC T6-T3 Gb. Ex tb IIIC T85-T139 Db. IP66/67 &  
IECEX: Ex db IIC T6-T3 Gb. Ex tb IIIC T85-T139 Db. IP66/67

| Supply      | Lamp output<br>Joules (J) | Model  | T rating & T amb   |
|-------------|---------------------------|--|--|
| 230VAC      | 30                        | 1E3-5E6  | T3 for -40°C to +70° C<br>T4 for -40°C to +65° C                           |
| 230VAC      | 25/21                     | 1E3-5E5<br>1E3-5E4   | T4 for -40°C to +70° C   |
| 230VAC      | 15                        | 1E3-5E3  | T4 for -40°C to +70° C<br>T5 for -40°C to +40° C                           |
| 230VAC      | 10/5                      | 1E3-5E2<br>1E3-5E1   | T4 for -40°C to +70° C<br>T5 for -40°C to +55° C<br>T6 for -40°C to +40° C |
| 110VAC      | 30/25/21                  | 1E3-4E6<br>1E3-4E5<br>1E3-4E4                                  | T4 for -40°C to +70° C   |
| 110VAC      | 15/10/5                   | 1E3-4E3<br>1E3-4E2<br>1E3-4E1                                  | T4 for -40°C to +70° C<br>T5 for -40°C to +55° C<br>T6 for -40°C to +40° C |
| 24VDC/48VDC | 30/25/21                  | 1E3-3E6<br>1E3-3E5<br>1E3-3E4<br>1E3-2E6<br>1E3-2E5<br>1E3-2E4 | T4 for -40°C to +70° C   |
| 24VDC/48VDC | 15/10/5                   | 1E3-3E3<br>1E3-3E2<br>1E3-3E1<br>1E3-2E3<br>1E3-2E2<br>1E3-2E1 | T5 for -40°C to +70° C<br>T6 for -40°C to +60° C                           |

### LED Beacon Certified

ATEX: Ex II 2 GD Ex db op is IIC T6 Gb. Ex tb op is IIIC T85 Db. IP66/67 &  
IECEX: Ex db op is IIC T6 Gb. Ex tb op is IIIC T85 Db. IP66/67

| Supply                  | Lamp output                            | Model              | T rating & T amb       |
|-------------------------|--|--------------------|------------------------|
| 110~230 VA/<br>12~48VDC | 2700K(warm white)<br>5600K(cool white) | 1E3-5LS<br>1E3-3LS | T6 for -40°C to +70° C |

The IECEx certificate and product label carry the IECEx equipment protection level marking 'Gb' and 'Db'.



Where:

Gb mark denotes suitability for use in a Zone 1 & Zone 2 surface industries area in the presence of gas.

Db mark denotes suitability for use in a Zone 21 & Zone 22 surface industries area in the presence of dust.

The ATEX certificate and product label carry the ATEX group and category marking:

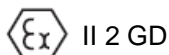

Where:

 mark denotes compliance with ATEX

The mark 'II' denotes suitability for use in surface industries.

The mark '2' denotes suitability for use in Zone 1 and Zone 2 area

The mark 'G' denotes suitability for use in the presence of gases

The mark 'D' denotes suitability for use in the presence of dusts

The ATEX certificate and product label also carry the following mark:



## Type Approval Standards

The beacons have been approved to the following standards:

ATEX units certified to EN60079-0, EN60079-1, EN60079-28 and EN60079-31.  
IECEX units certified to IEC60079-0, IEC60079-1 and IEC60079-28 and IEC 60079-31.

## Warranty Policy

### ONE YEAR LIMITED WARRANTY

Alphino Pte Ltd warrants its products to be free from defects in material and workmanship for a period of 1 year from the date of delivery. If a product or any part that proves to be defective in material or workmanship under normal installation, use and service during the warranty period, Alphino Pte Ltd will, at its sole option, repair or replace the product subject to the terms and conditions outlined below.

1. The product is returned to Alphino Pte Ltd or one of its authorized distributors with transportation charges prepaid.
2. Replacement product or parts may include re-manufactured or refurbished parts or components.
3. The replacement unit will be covered by the balance of the time remaining on the customer's original limited warranty.

Returned products must include a copy of the tax invoice. In the absence of tax invoice or proof of purchase, otherwise Alphino Pte Ltd reserves the right to charge for repair cost.

## WARRANTY LIMITATIONS

This warranty shall be void if the product is damaged as a result of defacement, misuse, abuse, neglect, accident, destruction or alteration of the serial number, improper electrical voltages or currents, repair, alteration or maintenance by any person or party other than a Alphino Pte Ltd employee or authorized service facility, or any use in violation of instructions furnished by Alphino Pte Ltd.



**Alphino Pte Ltd**  
**18 Boon Lay Way,**  
**#03-110 TradeHub 21,**  
**Singapore 609966**

**Tel: (65) 6686 4923**  
**Fax: (65) 6468 5819**

**Email: [enquiry@alphino.com](mailto:enquiry@alphino.com)**  
**Website: [www.alphino.com](http://www.alphino.com)**